

SINGLE STROKE CLEANER 3

Effective Port Cleaning Technology

Clyde Industries's Single Stroke Cleaner 3 (SSC 3) is designed to address the severe challenges faced in the recovery environment with advanced technology not found in any other cleaner on the market. With over 30 years as the world's leading supplier of port cleaning equipment and service, Clyde Industries has developed a low cost, low maintenance, single stroke port cleaner, unmatched in the industry.

Designed with simplicity in mind, the Single Stroke Cleaner 3 (SSC 3) houses a robust 4" diameter air cylinder to clean the toughest buildup. The cleaning head is designed for maximum airflow while closely matching the port opening profile and ultimately keeping the port clean.

Features include:

- Proprietary air cylinder designed for high heat applications
- Large diameter air cylinder can clean the most difficult buildup
- No exterior moving parts
- Large opening window allows for visual inspection
- Large cleaning head allows maximum air flow
- Cleaning head made with high temperature stainless steel and provides long service life
- Cleaning head designs for any size and shape port opening

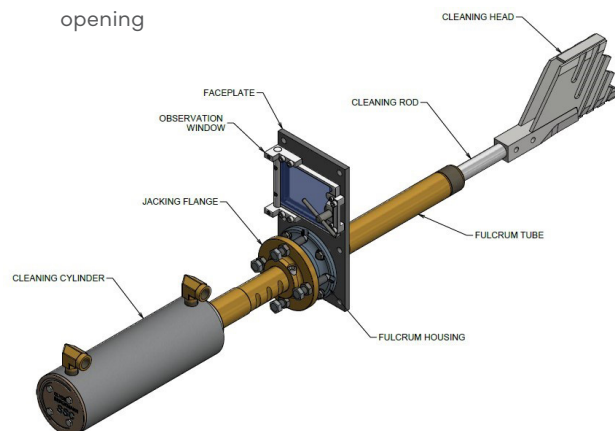

SINGLE STROKE CLEANER 3 DESIGNED SPECIFICALLY FOR HARSH ENVIRONMENTS

New Feature: Adjustable Fulcrum Tube

A revolutionary design feature with the SSC 3 is the cleaning head penetration can be adjusted further into or out of the boiler without removing the cleaner. Adjusting the cleaning head penetration is possible with the advent of the Adjustable Fulcrum Tube. The fulcrum tube has adjustable segments in 1-inch increments and allow a total of 8-inches of adjustments.

Why is the adjustable fulcrum tube needed?

Over time, the cleaning head will burn back and at some point will require replacement. With the recovery boiler in operation, cleaning head replacement has numerous safety concerns and requires careful planning. Even 1"-inch of burn back on a cleaning head will impact air flow and eventually affect boiler performance. At the secondary air level, eyebrow formations can disturb airflow and in some cases block airflow altogether. With the "Adjustable Fulcrum Tube", cleaning head penetration can be adjusted safely without exposing workers to this dangerous environment.

Specifications

- Air Cylinder 4-inch (100 mm) diameter and 8-inch stroke (200 mm)
- Cleaning head made with high temperature stainless steel
- Electrical 110 volts, 60 Hz solenoid valve
- Control panel stainless steel Nema 4X
- Air requirements 90 psi (6 bar) Instrument air recommended
- 220 volts or 24 volts available upon request

Benefits

- Easily adjust cleaning head penetration
- Safely adjust cleaning head without exposing workers to boiler hazards
- Spherical trunnion provides 100% seal against windbox combustion air
- Self-locking spherical design will not loosen.

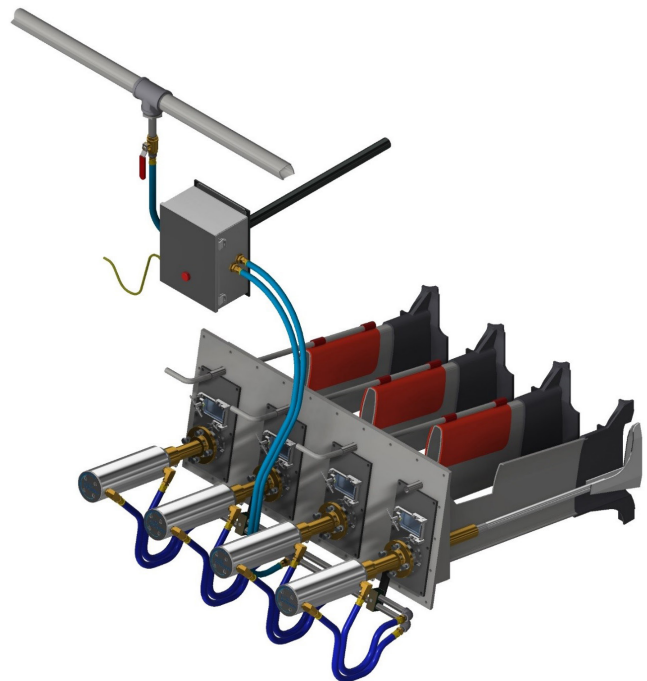

Clyde Industries Inc.
4015 Presidential Parkway | Atlanta | GA | 30340
+1 800 241 5996 | clyde-industries.com

COMPANY WITH
QUALITY SYSTEM
CERTIFIED BY DNV GL
= ISO 9001 =